

**TouchFly**

# **TouchFly Product Specification**

## **Motherboard Series**

CX6U01 Intel i7-6500U

V1.1

# Chapter One

## Product Description

### 1.1 Application scenario:

- ◆Advertising machine ◆Digital signage ◆Intelligent self-service terminal
- ◆Smart retail terminal ◆O2O smart equipment ◆Industrial smart automation equipment

### 1.2 Function introduction:

CX-6U01 V12 motherboard adopts Intel i7 series, which is a high-speed motherboard with silent fan. Mainly used in the fields of finance, retail, medical, all-in-one, advertising players, industrial computers, etc.

### 1.3 Function features:

- ◆Intel i7-6500U, main frequency 2.5GHZ adopts Intel Bay trail SOC chipset
- ◆Support DDR4 low voltage 1.2V memory, up to 16GB
- ◆Support wide voltage 12V-36V input, DC female head inner diameter 2.5MM
- ◆Onboard VGA/HDMI interface, LVDS interface; support dual-screen display
- ◆Onboard 2\*COM (standard RS232) port; 1\*RS485 and 1\*RS422 interconvertible; 4\*RS232 COM ports.
- ◆Onboard MiniPCIE, supports WIFI/3G; 1\*MSATA supports SATA SSD hard drives; 1\*M.2 supports M.2 2280 hard drives
- ◆Rich expansion interfaces: 8\*USB interfaces (2\*USB3.0 standard sockets, 2\*USB2.0 standard sockets, 2\*USB3.0 terminal interfaces, 2\*USB2.0 terminal interfaces); 4\*RS232 serial ports; 1\*RS422/RS485 ; 4\*GPIO (TTL) output, 4\*GPIO (TTL) input, which can meet the requirements of various peripherals on the market.

### Schematic diagram of motherboard frontside and backside interfaces:

frontside / backside:

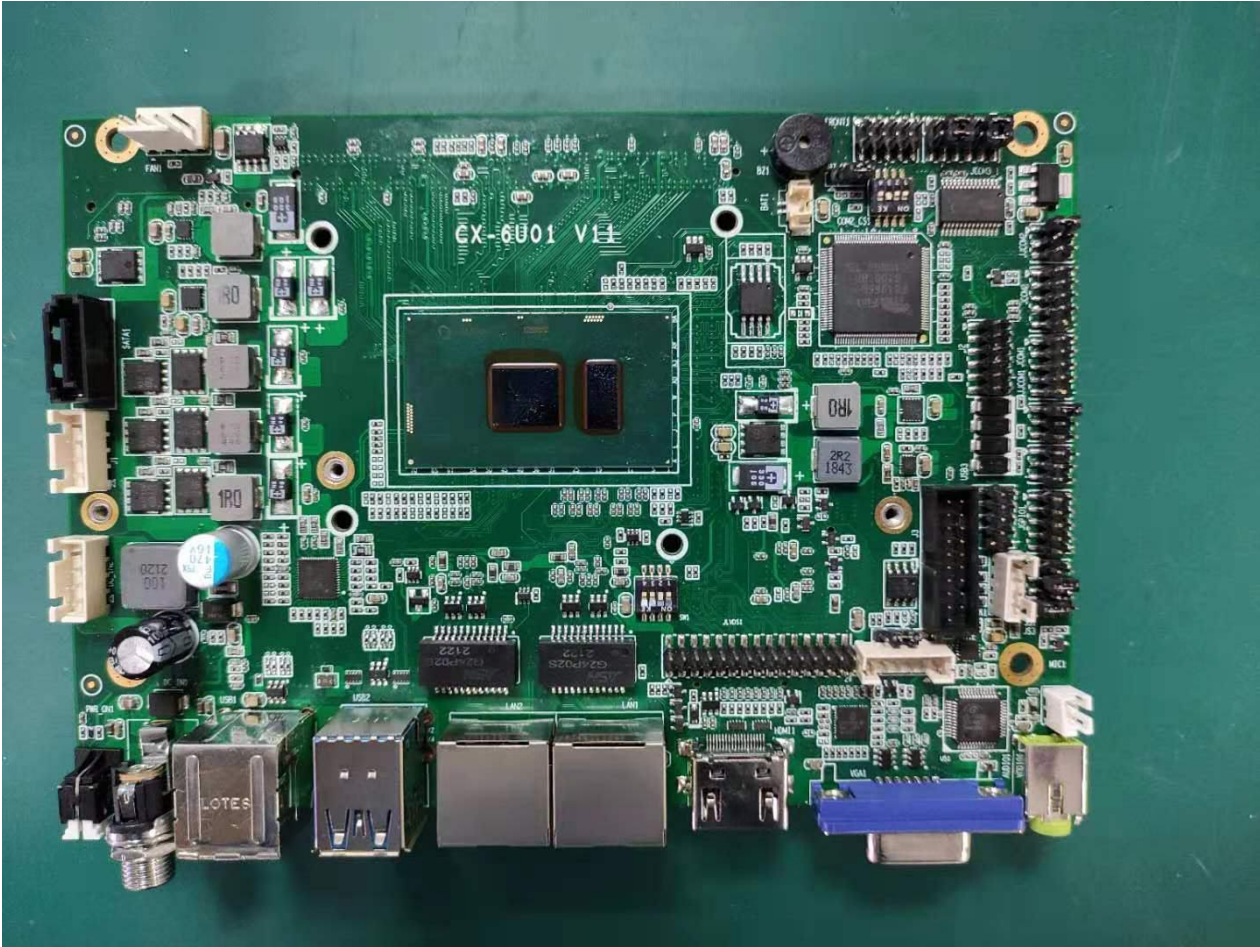

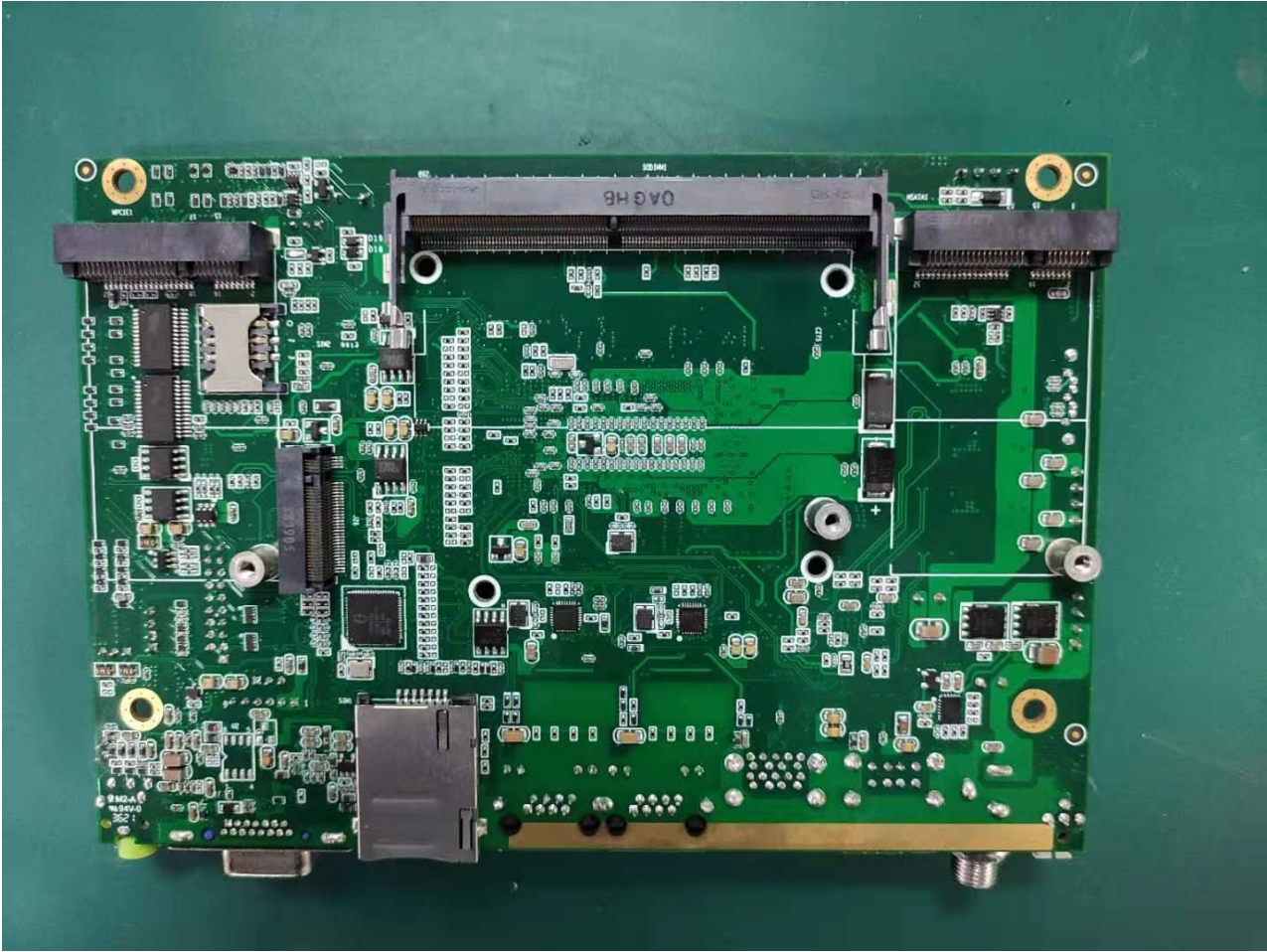

## Basic Function List

Components		Parameter/Specification
<b>CPU</b>		◆CX-I7 (6500U)Base frequency:2.5GHZ,Burst frequency:3.1GHZ,dual-core 4 threads
<b>Chipset</b>		Intel Bay trail SOC
<b>Memory</b>		Support DDR4-2133, 1 * SO-DIMM Slot, Maximum 16GB
<b>SATA</b>		1 * SATA3.0 + 1 * mSATA + 1*M.2
<b>FAN</b>		Silent fan
<b>OS Support</b>		Windows7 Professional Edition/Windows7 Ultimate Edition/Windows10 Professional Edition/Windows10 Enterprise Edition/Windows10 Home Edition/Win11 Professional Edition
		Ubuntu16.04.7/Ubuntu18.04.5/Ubuntu20.04.3
		Centos7.6/Centos7.8
<b>Display</b>	<b>LVDS</b>	Supported
	<b>EDP</b>	Supported(diff-version)
	<b>VGA</b>	Resolution up to 1920*1200@60HZ
	<b>HDMI</b>	1080P@120Hz,4kx2k@60Hz
<b>I/O</b>	<b>USB2.0</b>	4*(External port*2,internal port*2)
	<b>USB3.0</b>	2*External port
	<b>GPIO</b>	Eight I/O Pins
	<b>232</b>	6*(a RS232/RS422/RS485 switchable port)
	<b>422</b>	1* RS232/RS422/RS485 switchable port
	<b>485</b>	1* RS232/RS422/RS485 switchable port

<b>Internet</b>	<b>WIFI,BT</b>	1*Mini-PCIE port,WiFi module optional
	<b>3G/4G</b>	1*Mini-PCIE port,4G module optional
	<b>Ethernet</b>	2 * Realtek PCI-E NIC RTL8111H for 1000Mbps(dual gigabit internet optional)
<b>Audio</b>		1*MIC MIC input supported
		1*SPK 8Ω5W dual-channel output
		1*AUDIO audio input/output supported
<b>Timing Turn on/off</b>		Supported (Automatic boot when power connected)
<b>Power Supply</b>		5525 screw with wild range power input(12V~36V)
<b>ESD</b>		8KV contacted,15KV air
<b>Dimensions</b>		160mm*110mm*27mm
<b>Environment</b>		Operating temperature:-20°C~60°C; Operating humidity:5%~95%

# Chapter One:Interface definition and configuration instructions

## 3.1 Interface serial number identification

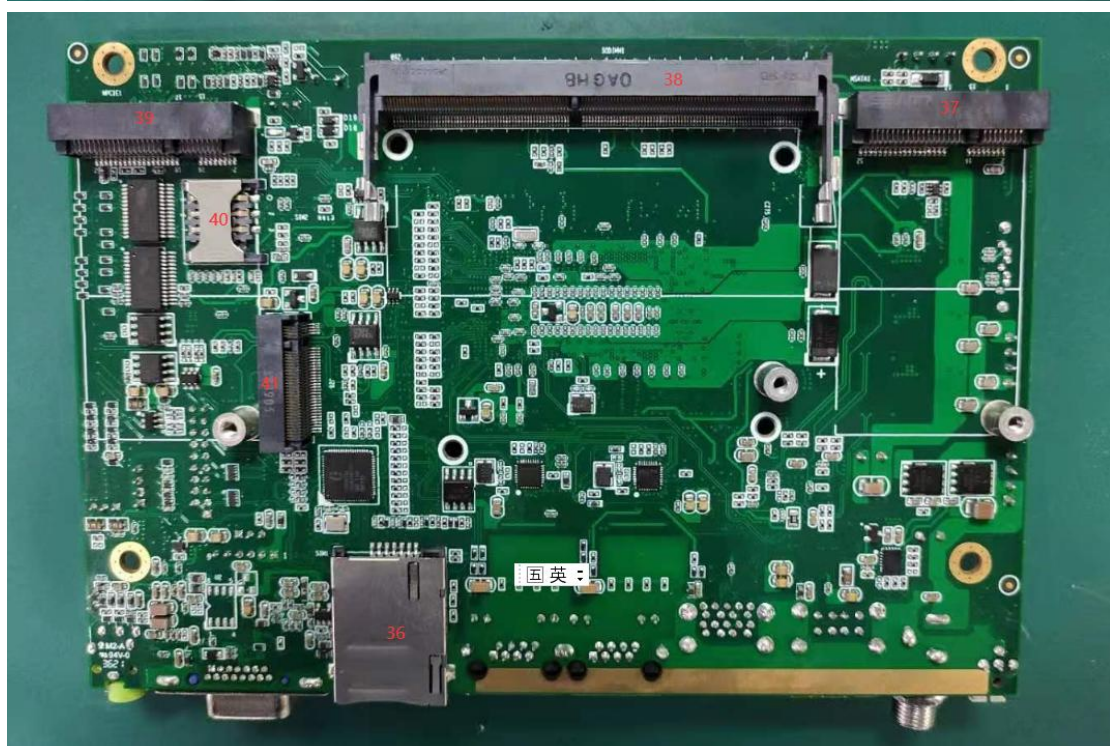
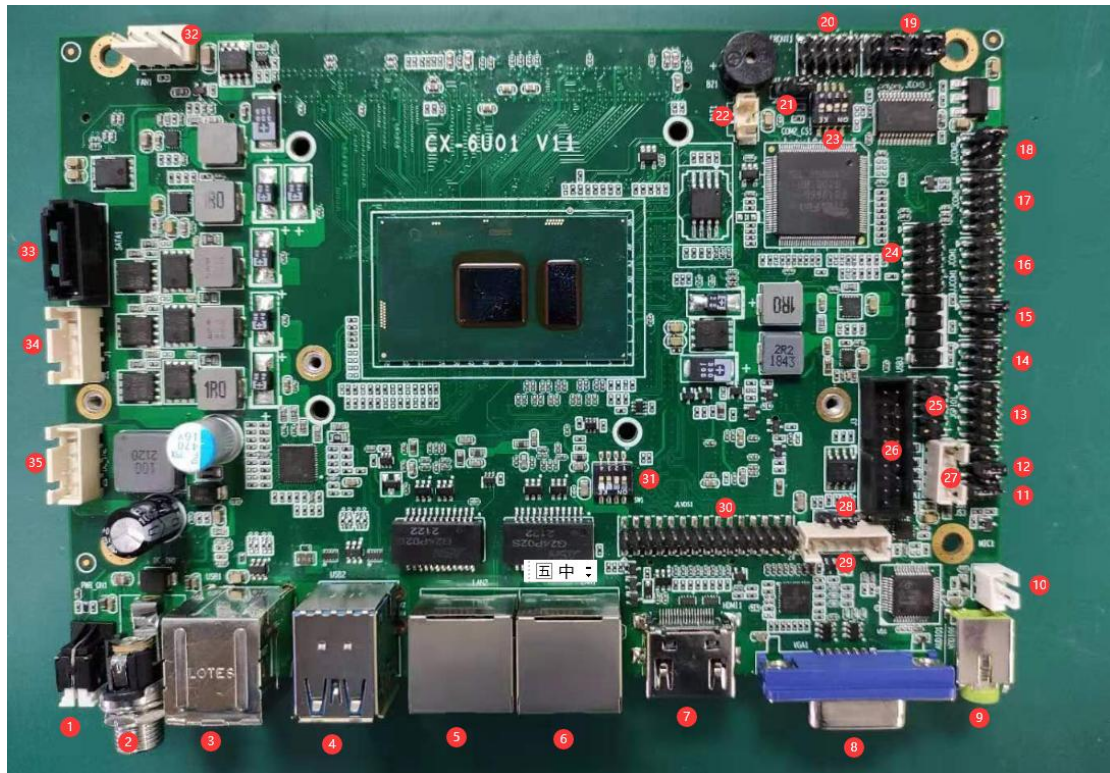

### 3.2 Interface serial number description

1. POWER KEY	21.AT/ATX optional
2.DC input	22.RTC terminal
3.USB 2.0 socket	23.RS232/RS422/RS485Encoder
4.USB 3.0 socket	24.Debug interface
5.RJ45 LAN (1000M)	25.USB 2.0 terminal
6.RJ45 LAN(1000M)	26.USB 3.0 terminal
7. HDMI video output	27.Speaker terminal
8.VGA video output	28.Dimming method selection
9.AUDIO socket	29.Backlight interface
10. MIC terminal	30.LVDS interface
11.GPIO Power selection	31.LVDS Encoder
12.LVDS Power selection	32.Fan interface
13.GPIO interface (TTL)	33.SATA
14.RS232/RS422/RS485terminal	34.SATA power
15.COM1 Voltage selection	35.Power input port
16.COM1 (full signal RS232)	36.SIM1
17.COM2 (full signal RS232)	37.MSATA
18.COM2 Voltage selection	38.Memory slot
19.4*RS232 COM Ports	39.MiniPCIE (3G/4G/WiFi)
20.Front Jumper	40.SIM2
	41.M.2 interface 2280

### 3.3Interface terminal definition description

#### 3.3.1 MIC







### 3.3.2 Backlight interface

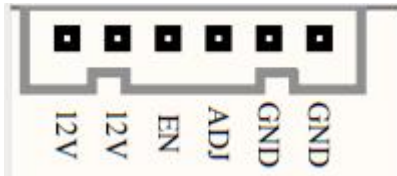

29

### 3.3.3 LVDS interface

30

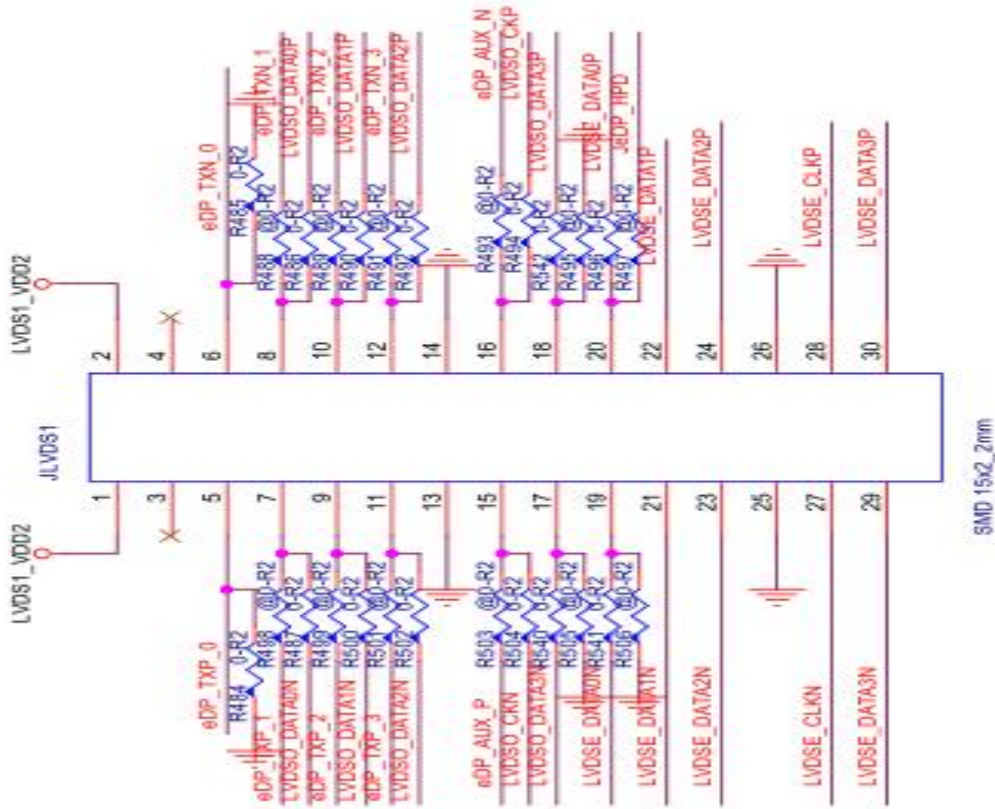

### LVDS Definition of resolution dial code

- 0-0000-1024\*600-1CH/18bit
- 1-0001-1024\*768-1CH/18bit
- 2-0010-800\*600-1CH/18bit
- 3-0011-1280\*800-1CH/18bit
- 4-0100-1920\*1080-2CH/24bit special mode
- 5-0101-1680\*1050-2CH/24bit

31

6-0110-800\*600-1CH/24bit  
7-0111-1024\*768-1CH/24bit  
8-1000-1024\*600-1CH/24bit

9-1001-1280\*800-1CH/24bit  
10-1010-1920\*1080-2CH/18bit  
11-1011-1366\*768-1CH/24bit  
12-1100-1920\*1200-2CH/24bit  
13-1101-1280\*1024-2CH/24bit  
14-1110-1440\*900-2CH/24bit    15-1111-1920\*1080-2CH/24bit

**0000-1111** a total of 16 bits correspond to the code switch 4 3 2 1

### 3.3.4 Dimming method selection

28



Default is PWM mode

### 3.3.5 USB 3.0 terminal

26

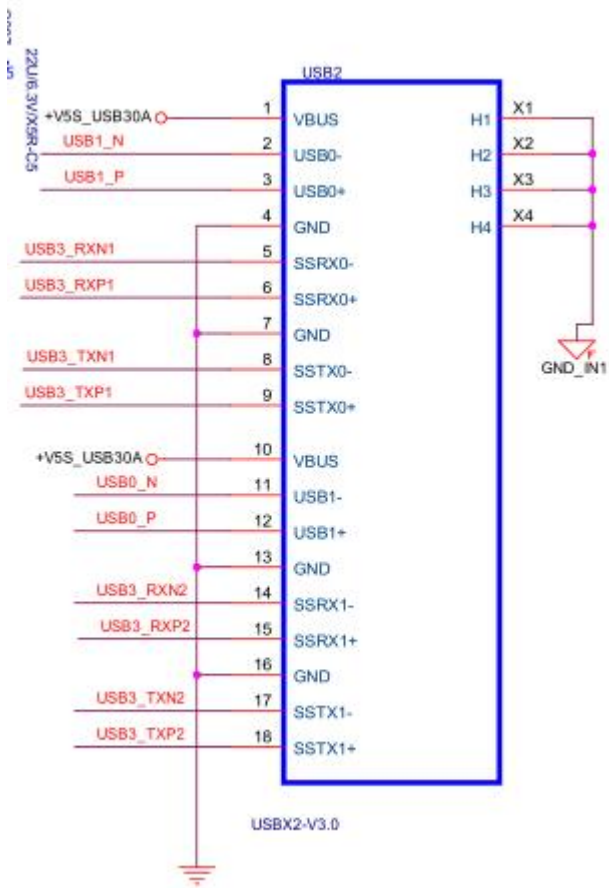

### 3.3.6 Speaker terminal

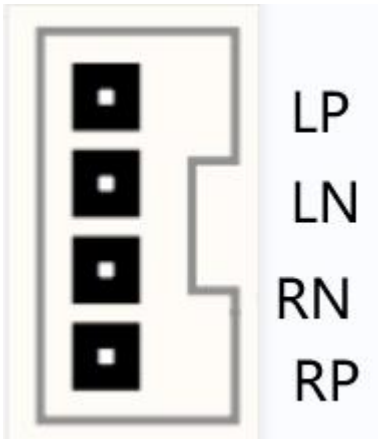

27

### 3.3.6 USB 2.0 terminal

25

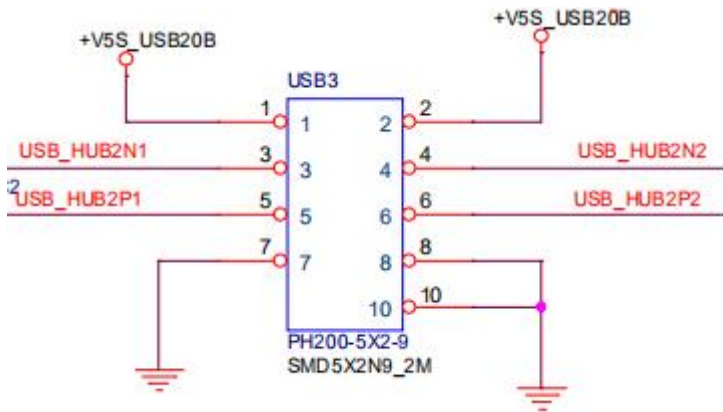

### 3.3.7 GPIO Power selection

11



### 3.3.8 LVDS Power supply options

12

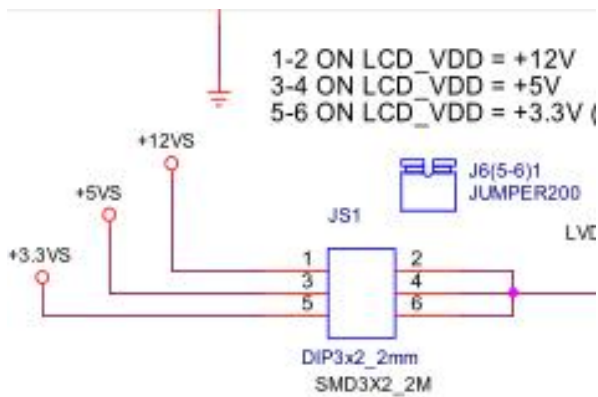

### 3.3.9 GPIO interface (TTL)

13

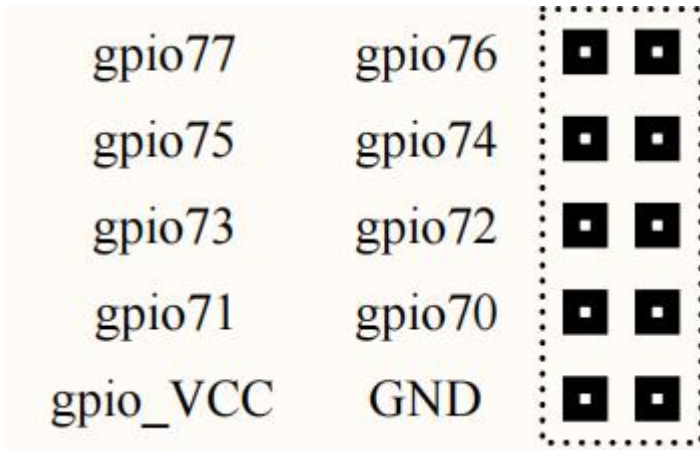

Under the main BIOS interface, select the F81866/F81966 super IO menu under the advanced interface;

The information for setting IO is as follows:

(000F)		Yes	Default		
(00A3)	GPIO Modules Mode Settings	Yes	Default		
(00A4)	GPIO 70 Controller	Yes	Default	Input	Input
(00A5)	GPIO 71 Controller	Yes	Default	Input	Input
(00A6)	GPIO 72 Controller	Yes	Default	Input	Input
(00A7)	GPIO 73 Controller	Yes	Default	Input	Input
(00A8)	GPIO 74 Controller	Yes	Default	Output High	Output High
(00A9)	GPIO 75 Controller	Yes	Default	Output High	Output High
(00AA)	GPIO 76 Controller	Yes	Default	Output High	Output High
(00AB)	GPIO 77 Controller	Yes	Default	Output High	Output High
(000F)		Yes	Default		

Program writing: GPIO70-77 control register address is 0xA03, 8-bit status value corresponds to GPIO (xxxx xxxx); read during input, write during output;

### 3.3.11 COM1/COM2 voltage selection

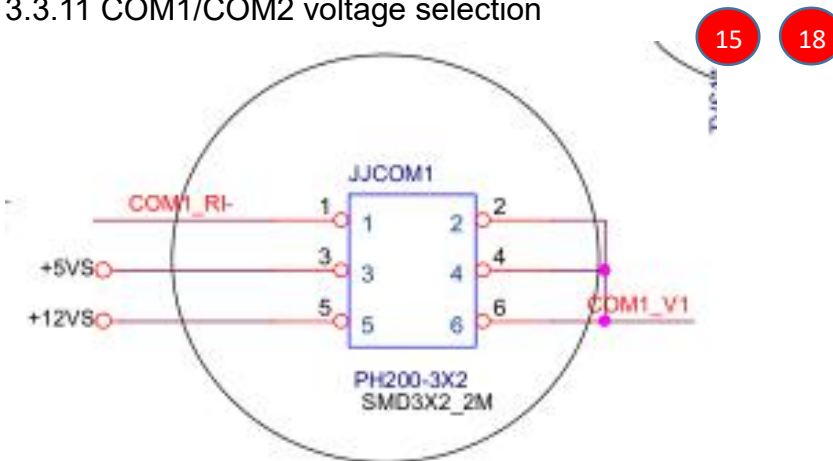

3-4 output: 5V

5-6 output: 12V

### 3.3.12 COM1/COM2 (full signal RS232) Interface definition

16 17

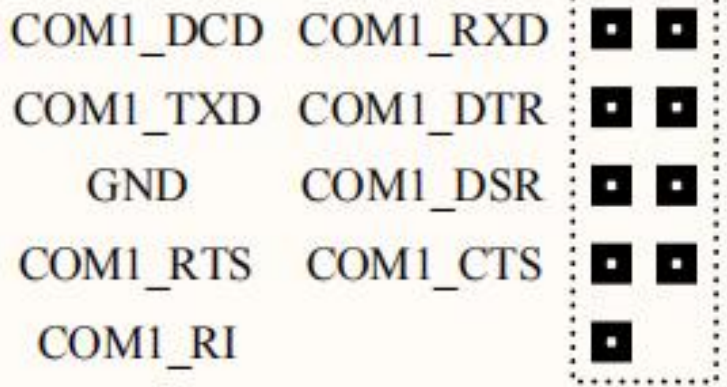

3.3.13 4\*RS23 COM

19

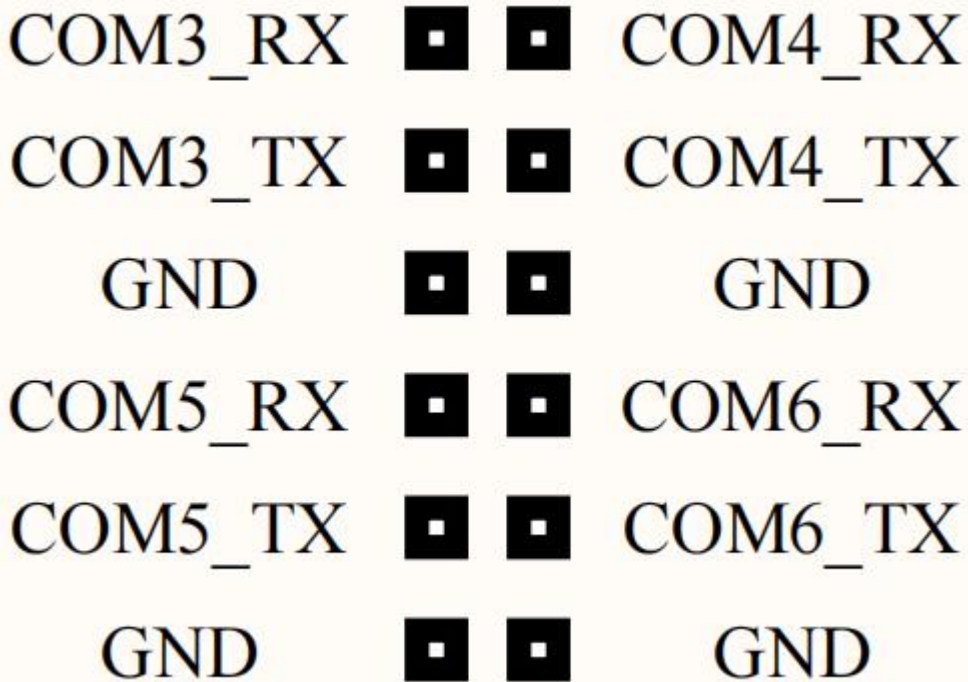

3.3.13 FRONT Jumper Interface definition

20

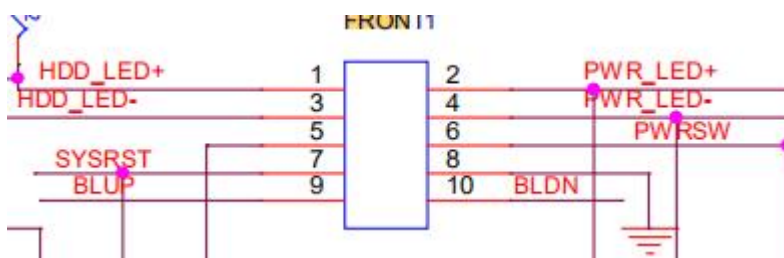

3.3.14 RTC terminal

22

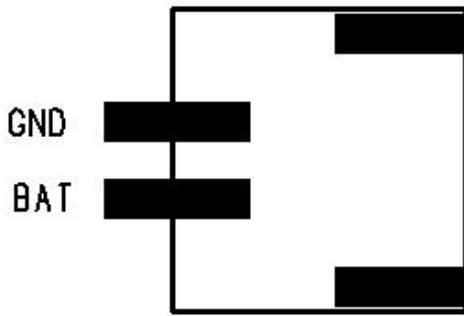

### 3.3.15 AT/ATX optional

21



AT Mode: Power on does not automatically start the computer.

ATX Mode: Power on automatically starts the computer.

### 3.3.14 RS232/RS422/RS485 Encoder

23 14

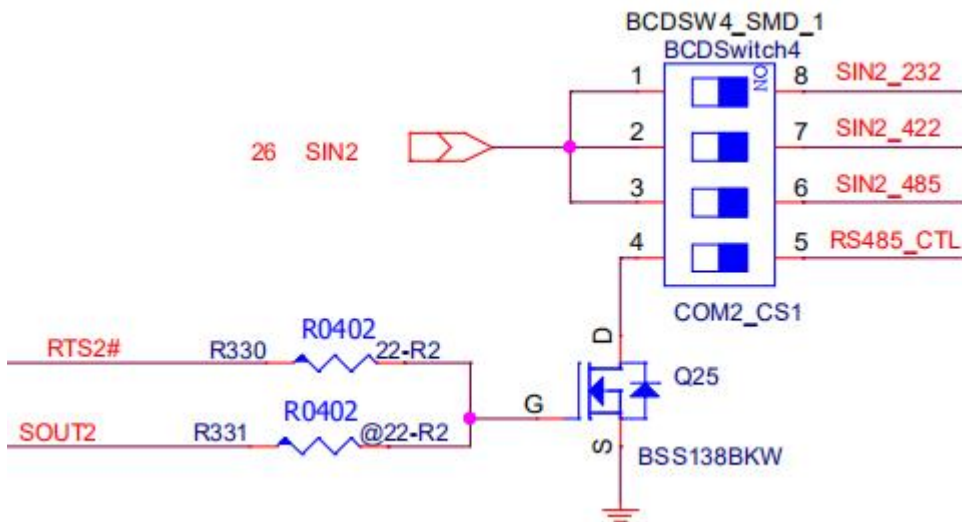
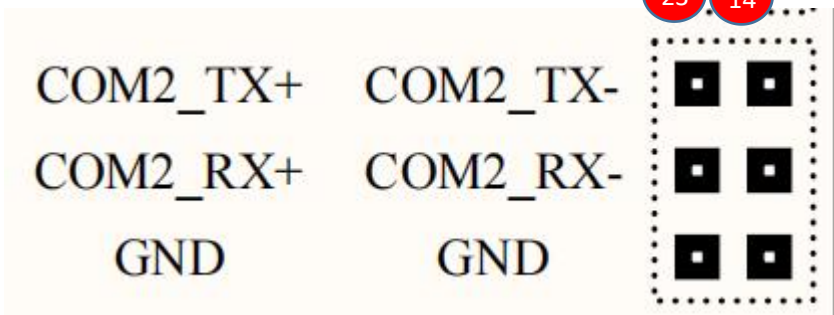

1 ON COM2 Select 232

2 ON COM2 Select 422  
 3 4 ON COM2 Select 485

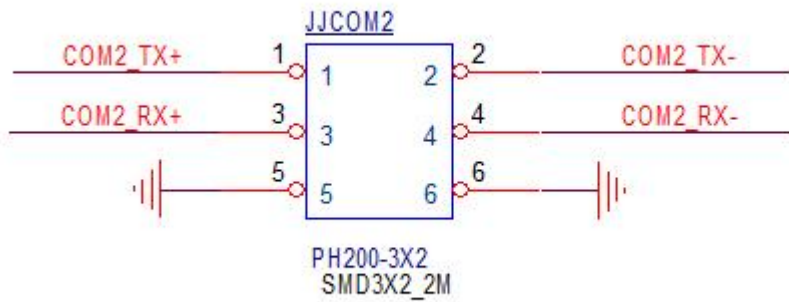

RS422 mode: COM2\_TX+ 、 COM2\_TX- 、 COM2\_RX+、 COM2\_RX-  
 RS485 mode: RS485+COM2\_TX+、 RS485-COM2\_TX-

### 3.3.15 fan interface

32

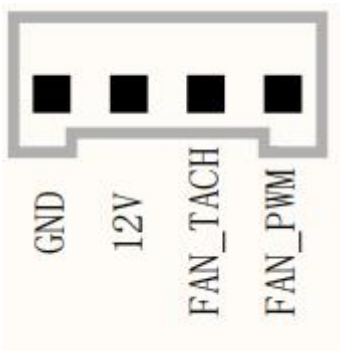

### 3.3.15 SATA

33

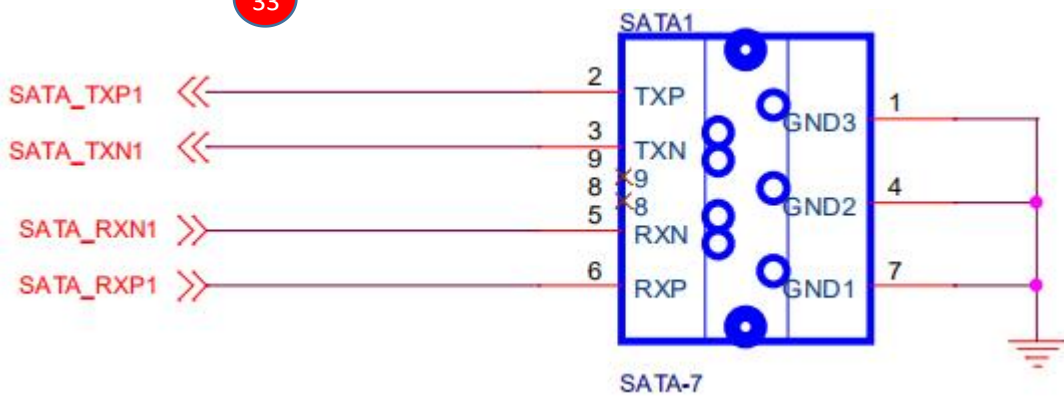



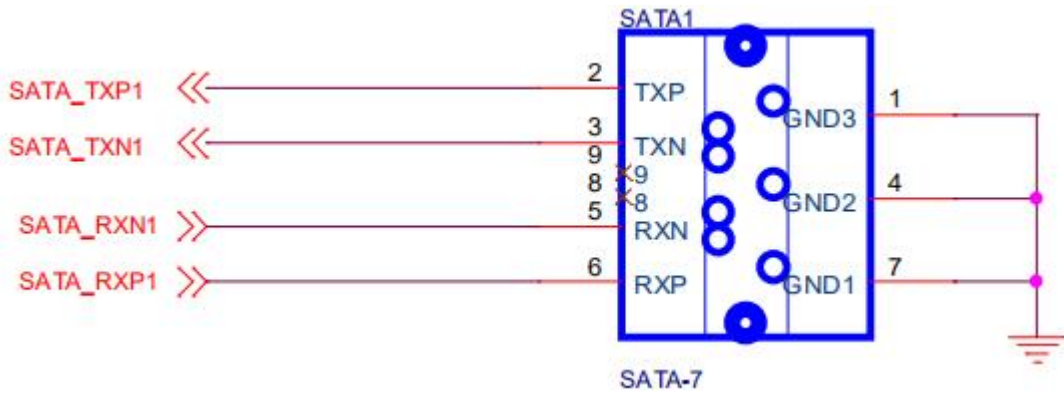

3.3.15 SATA POWER interface definition

34

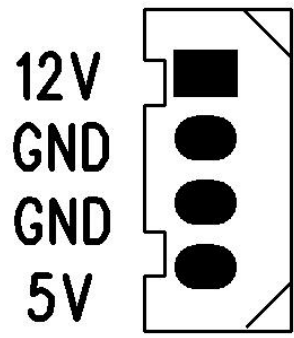

3.3.16 Power input interface definition

35

